



EVENT (300 / 500 / 700)

Residential Type Heat Recovery Unit



Assembly & Maintenance Guide



EN

Introduction	Page 1
Warnings & Safety Informations	Page 2
Check List	Page 3
Unit Components	Page 4
Technical Data	Page 5
Installation	Page 9
Montage-Service-Maintenance Info	Page 11
Selection of Electrical Cable Cross-Section	Page 14

INTRODUCTION

Installation&Operation Manual has been prepared and given to customer as a guide for easy installation&operation units manufactured by ENEKO A.Ş. The manual contains description of the unit, components and basic informations and recommendations for proper and fail free operation. Please read the instructions and warnings given in this manual before starting installation, operation and maintenance works and keep this manual near the unit, within easy reach of service personnel.



Any damage, failure or hazard occurred because of use except this purpose is beyond the responsibility of manufacturer.



For technical service and questions, please contact with following information.



+90 232 328 20 80 / 103-152



+90 536 713 10 00



www.eneko.com.tr



servis@eneko.com.tr

WARNINGS & SAFETY INFORMATION



PROHIBITED

- ◆ This unit has to be used under proper conditions according to its technical specification and design purpose. (Otherwise responsibility belongs to practitioner)
- ◆ Unauthorized personnel must not interfere in unit and/or must not use unoriginal spare parts. (Otherwise responsibility of failure that may occur belongs to practitioner)
- ◆ Do not install this product in a refrigerated warehouse, heated swimming pool or other location where temperature and humidity are significantly different. (Failure to heed this warning may result in electrical shock or malfunctioning.)
- ◆ Do not install this product where it will be directly exposed to rain. (Failure to heed this warning may result in electrical shock or malfunctioning.)
- ◆ Do not install this product in a location where acid, alkali or organic solvent vapors, paints or other toxic gases, gases containing corrosive components or high concentrations of oily smoke are present (Failure to heed this warning may result not only in malfunctioning but also fire, power leakage and electrical shock.)
- ◆ Do not use this product outside the range of its rated voltage and control capacity.



ATTENTION

- ◆ Install this product in an environment where the temperature ranges from $-10\text{ }^{\circ}\text{C}$ to $+40\text{ }^{\circ}\text{C}$ and the relative humidity is less than 60%. If condensation is expected to form, heat up the fresh outside air by a duct heater etc.
- ◆ Select an adequately sturdy position for installing the product and install it properly and securely.
- ◆ Use the designated electrical wires for the terminal board connections and connect the wires securely so that they will not be disconnected. (Failure to ensure proper connections may result in fire.)
- ◆ When passing metal ducts through wooden buildings clad with metal laths, wire laths or metal, these ducts must be installed in such a way that they will not make electrical contact with metal laths, wire laths or metal sheets. (Power leakage can cause ignition.)
- ◆ The outside ducts must be tilted at a gradient (1/30 or more) downwards toward the outdoor area from the main unit, and properly insulated. (The entry of rain water may cause power leaks, fire or damage to household property.)
- ◆ Gloves should be worn while installation. (Failure to heed this warning may result in injury.)
- ◆ A dedicated circuit breaker must be installed at the origin of mains power supply. This circuit breaker must be provided with a means for locking (lock and key).
- ◆ The body of the unit, room control panel and cables keep away the unit 3 m. distance.



- ◆ This product must not be disassembled under any circumstances. Only authorized repair technicians are qualified to conduct disassembly and repairs. (Failure to heed this warning may result in fire, electrical shock or injury.)



- ◆ Connect the product properly to the ground. (Malfunctioning or power leaks can cause electrical shock.)



- ◆ An isolator switch having minimum contact gap of 3 mm in all poles must be provided as a means of disconnecting the power supply.

NOTE: The installations, which is not available for installation and operation manual, is out of guarantee.

CHECK LIST

In the event of unit failure and pre-commissioning checks to be made are determined as follows; after checking this information, please contact our company in case failure continues.

Controls

√

Make sure that the unit receives power and electrical grounding is made!

Make sure that the electricity cables are drawn from in the correct cross section!
(Please check whether there is heating on cables or not.)

Please check whether the cables in unit control panel are shielded (shielded magnetic field) or not; make sure shielding is grounded. If not, please change them!

Make sure that fresh air and exhaust air filters are clean and they do not block the flow of air!

Make sure there is the connection of drainage on the unit, check any possible clogging in drainage line and clean if necessary!

Please check whether the diameter of the air duct connection of the unit and the diameter of the spigot are the same. If the duct connection is smaller, change it with the correct one.

Make sure the electrical connections of the unit are made as suggested on the unit and in this guide, check if there is incorrect connection.

Make sure during the installation of the unit there is enough space for the service and if there is not enough space, re-install again.

In extremely cold climate applications, frost may occur on the exchanger, apply electric heater in fresh air intake section of the unit to get the temperature to -5 °C and above.

After installing the unit, make sure that it does not create an abnormal sound or vibration, if there is, make sure that rubber pads are used.

EVENT 300

EVENT 300 units are designed for recovering part of the energy of the exhausted air in a ventilation system. The recovered energy is directly transferred to the supplied fresh air, that reduces the necessary load on the air conditioning system.

- 1 Control Unit
- 2 Filters
- 3 Actuator
- 4 Heat Recovery Exchanger
- 5 Main Frame
- 6 Fans

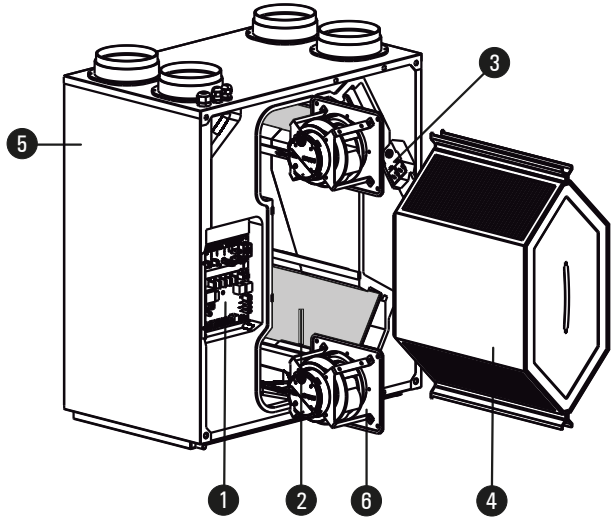

EVENT 500 / 700

EVENT 500/700 units are designed for recovering part of the energy of the exhausted air in a ventilation system. The recovered energy is directly transferred to the supplied fresh air, that reduces the necessary load on the air conditioning system.

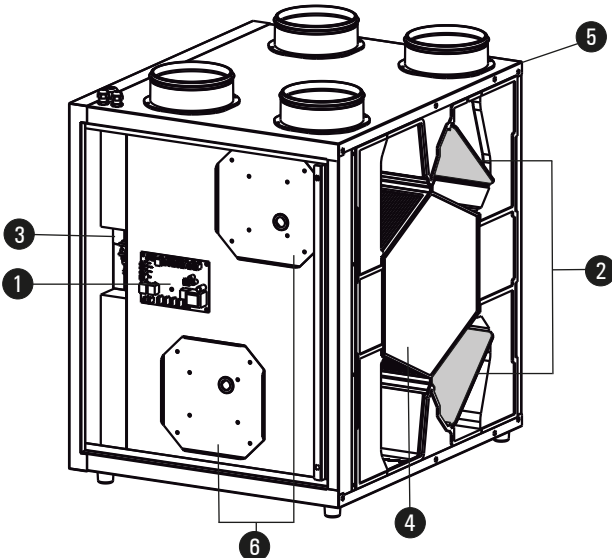

- 1 Control Unit
- 2 Filters
- 3 Actuator
- 4 Heat Recovery Exchanger
- 5 Main Frame
- 6 Fans

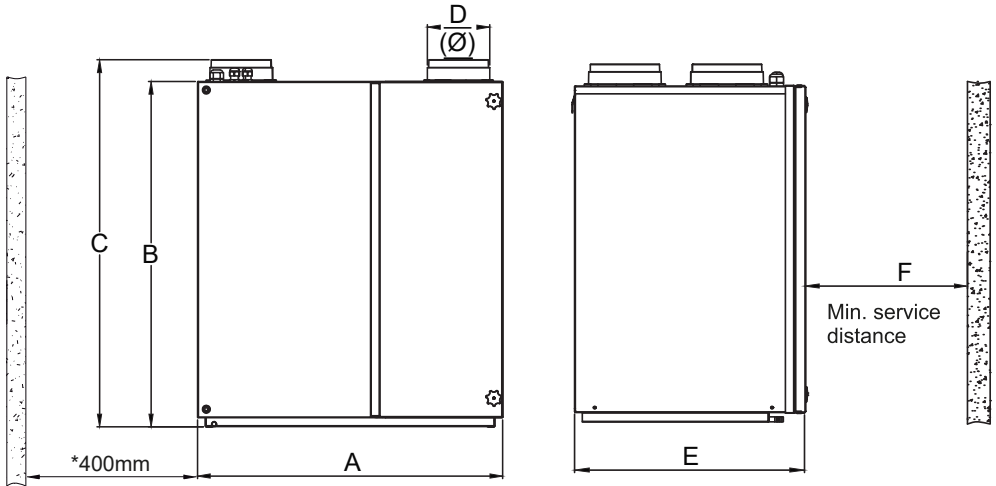

		EVENT 300	EVENT 500	EVENT 700
Dimensions(mm)	A	600	700	700
	B	680	725	725
	C	720	785	785
	D	∅ 125	∅ 160	∅ 200
	E	390	620	620
	F	400	600	600
Filter Class / Type		According to EN 779 G Class Synthetic Filter (F class as optional)		
Weight (kg)		24	41	41

* For Event 500 and 700.

		EVENT 300		
		Manual Control (no DCV)	Clock Control (no DCV)	Central Demand Control
SEC ¹	Average	-32.68	-33.75	-35.82
	Warm	-8.71	-9.65	-11.48
	Cold	-69.93	-71.21	-73.71
SEC class		B	B	A
Typology		Bidirectional		
Type of drive		Multi-speed ⁴		
Heat recovery system		Recuperative		
Thermal efficiency	%	86.1		
Maximum flow rate (@100Pa)	m ³ /h	220		
Electrical power input at maximum flow	W	112		
Sound power level at reference flow rate	L _{wa}	57.4		
Reference flow rate	m ³ /s	0.043		
Reference pressure difference	Pa	50		
SPI	W(m ³ /h)	0.366		
MISC		1.1		
CTRL		1	0.95	0.85
Declared leakage rates	Internal	<%3		
	External	<%3		
Mixing rate	%	0		
Position and description of filter warning		www.eneko.com.tr		
Instruction of grilles		www.eneko.com.tr		
Internet address		www.eneko.com.tr		
AEC ²	Average	5.1	4.7	4.0
	Warm	4.6	4.2	3.6
	Cold	10.4	10.1	9.4
AHS ³	Average	44.9	45.2	45.6
	Warm	20.4	20.4	20.6
	Cold	88.0	88.4	89.2

¹ Specific Energy Consumption [kWh/(m².a)]

² Annual Electricity Consumption [kWh/a electric per year]

³ Annual Heating Saved [kWh fuel gross calorific value per year]

⁴ If a sensor or a pressure transmitter is used in the system, the device can work at variable speed.

		EVENT 500		
		Manual Control (no DCV)	Clock Control (no DCV)	Central Demand Control
SEC ¹	Average	-36.23	-37.07	-38.69
	Warm	-11.49	-12.24	-13.71
	Cold	-74.82	-75.81	-77.72
SEC class		A	A	A
Typology		Bidirectional		
Type of drive		Multi-speed ⁴		
Heat recovery system		Recuperative		
Thermal efficiency	%	90.5		
Maximum flow rate (@100Pa)	m ³ /h	370		
Electrical power input at maximum flow	W	169		
Sound power level at reference flow rate	L _{wa}	57.3		
Reference flow rate	m ³ /s	0.072		
Reference pressure difference	Pa	50		
SPI	W(m ³ /h)	0.297		
MISC		1.1		
CTRL		1	0.95	0.85
Declared leakage rates	Internal	<%3		
	External	<%3		
Mixing rate	%	0		
Position and description of filter warning		www.eneko.com.tr		
Instruction of grilles		www.eneko.com.tr		
Internet address		www.eneko.com.tr		
AEC ²	Average	4.2	3.9	3.4
	Warm	3.7	3.4	2.9
	Cold	9.5	9.3	8.7
AHS ³	Average	46.3	46.4	46.7
	Warm	20.9	21.0	21.1
	Cold	90.5	90.8	91.3

¹ Specific Energy Consumption [kWh/(m².a)]

² Annual Electricity Consumption [kWh/a electric per year]

³ Annual Heating Saved [kWh fuel gross calorific value per year]

⁴ If a sensor or a pressure transmitter is used in the system, the device can work at variable speed.

		EVENT 700		
		Manual Control (no DCV)	Clock Control (no DCV)	Central Demand Control
SEC ¹	Average	-31.15	-32.34	-34.65
	Warm	-6.99	-8.07	-10.15
	Cold	-68.75	-70.13	-72.83
SEC class		B	B	A
Typology		Bidirectional		
Type of drive		Multi-speed ⁴		
Heat recovery system		Recuperative		
Thermal efficiency	%	87.2		
Maximum flow rate (@100Pa)	m ³ /h	570		
Electrical power input at maximum flow	W	333		
Sound power level at reference flow rate	L _{wa}	57.0		
Reference flow rate	m ³ /s	0.111		
Reference pressure difference	Pa	50		
SPI	W(m ³ /h)	0.425		
MISC		1.1		
CTRL		1	0.95	0.85
Declared leakage rates	Internal	<%3		
	External	<%3		
Mixing rate	%	0		
Position and description of filter warning		www.eneko.com.tr		
Instruction of grilles		www.eneko.com.tr		
Internet address		www.eneko.com.tr		
AEC ²	Average	5.8	5.4	4.6
	Warm	5.3	4.9	4.2
	Cold	11.1	10.8	10.1
AHS ³	Average	45.3	45.5	45.9
	Warm	20.5	20.6	20.7
	Cold	88.6	89.1	89.7

¹ Specific Energy Consumption [kWh/(m².a)]

² Annual Electricity Consumption [kWh/a electric per year]

³ Annual Heating Saved [kWh fuel gross calorific value per year]

⁴ If a sensor or a pressure transmitter is used in the system, the device can work at variable speed.

INSTALLATION

Wall Montage

1. Mount the wall bracket with screw. (3 piece of $\varnothing 5 \times 40$ screw and fixing plug.)
2. Make sure that the unit is properly fit on the bracket.
3. For set the level of unit use screw on figure 3.

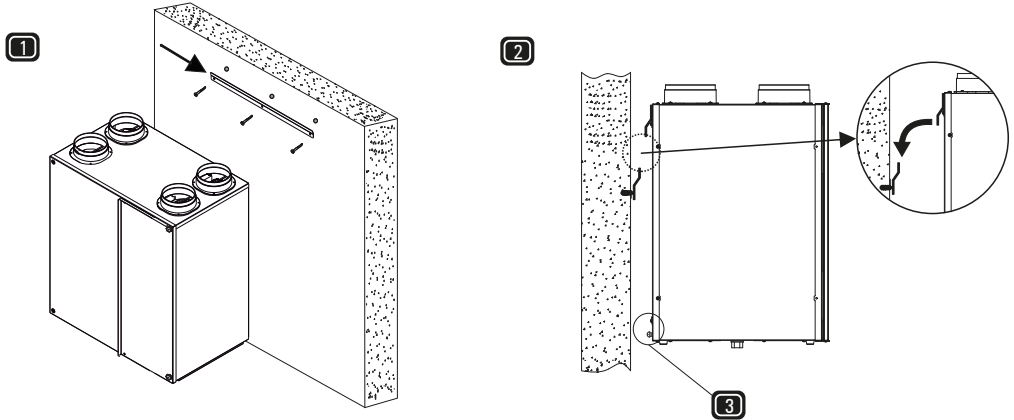

Floor Montage

The EVENT 300 device can be placed directly on level ground. For EVENT 500 and EVENT 700 to easy montage of the drain, give a gap at least 110mm between floor and unit.

Event 300

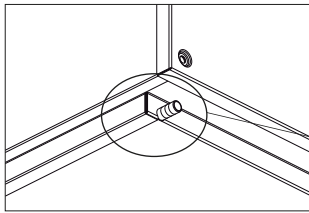

Drain connection size is 10 mm.

Event 500-700

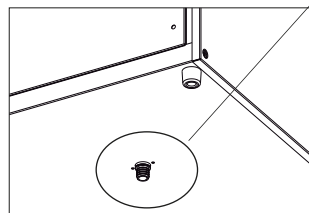

Drain connection size is 20 mm.

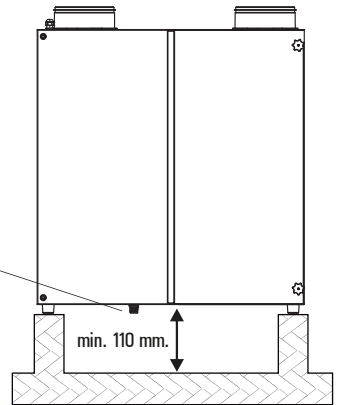

- For safety of components, condensing water needs to be drain from unit.
- For easy cleaning use connector or pipe clip on drain connection.
- Use bigger size of connection hose then drain size.
- Use spyhon after the drain connection.

INSTALLATION

Gasket Installation

Gasket is used to ensure tightness. It can be easily installed or removed without needing a tool as shown below. (Gaskets will be attached on the unit).

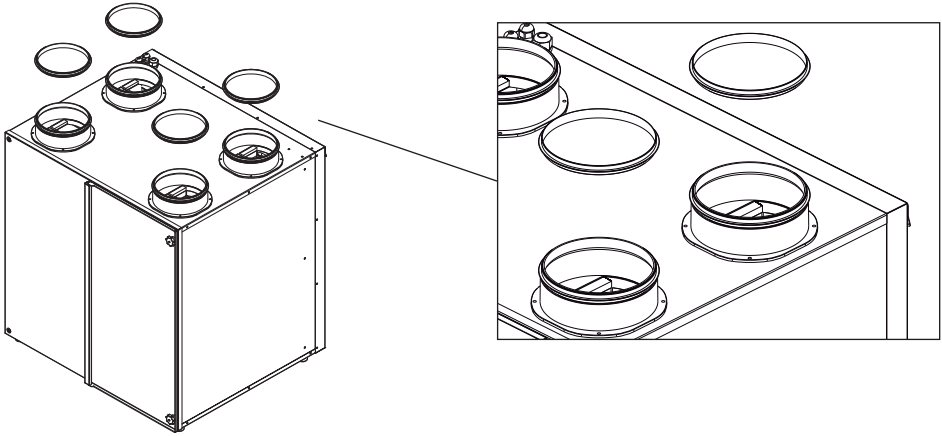

Preheater Installation

- Install supply air temperature sensor (Tsa) min. 250 mm after the postheater

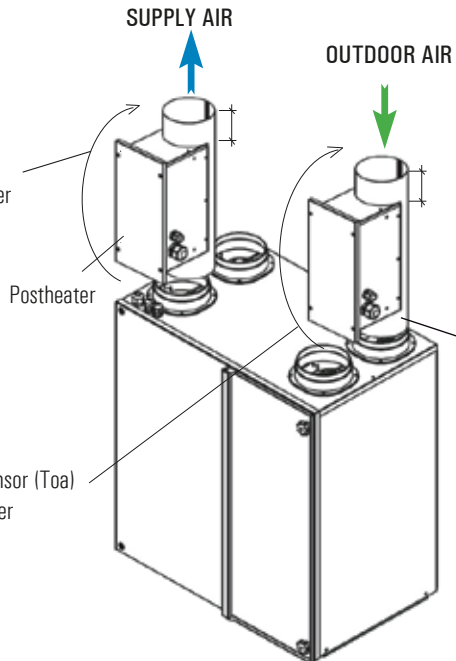

- Install outdoor temperature sensor (Toa) min. 250mm before the preheater

NOTE: For preheater or postheater option the standart 3 meter sensor cable comes with unit.

EVENT 300

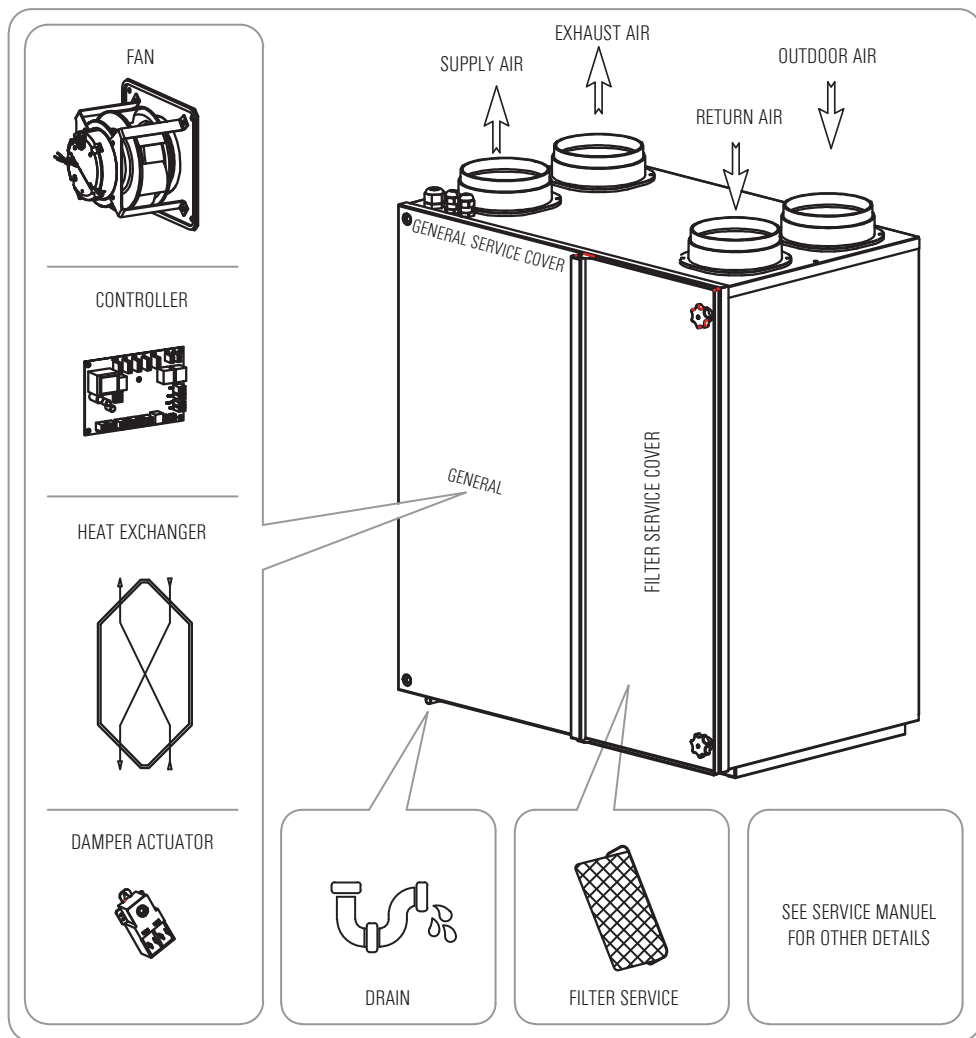

EVENT 500 / 700

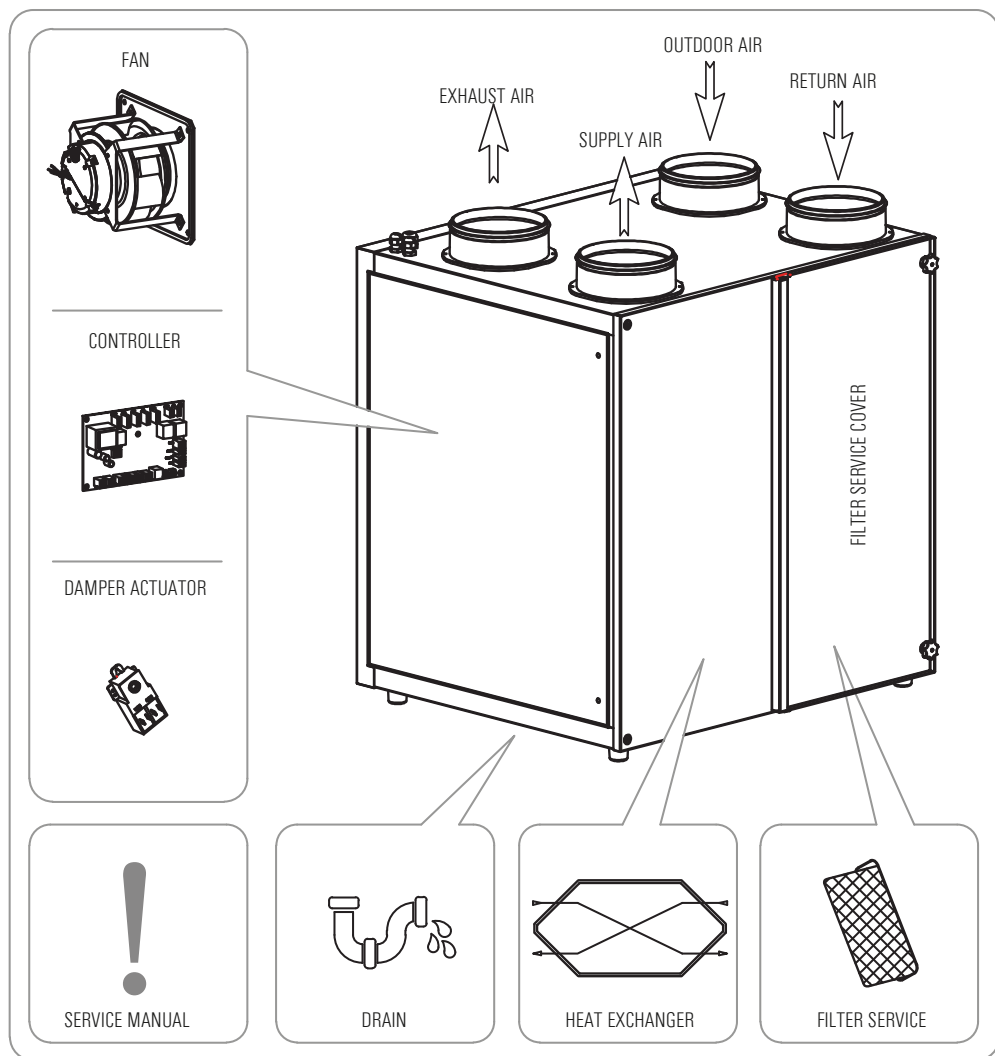

- ◆ Before the maintenance close main power switch.
- ◆ Do not run the unit without filters, it will be cause of harm other components.
- ◆ Clean the filters every month, change in a 6 month period. (Depending on working conditions.)
- ◆ Clean heat exchanger every 2 year.

Filter Cleaning

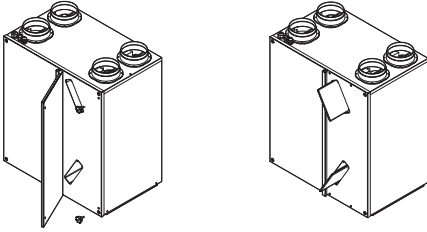

Open the service door.

Take out the filters.

1. Step: Unscrew the service door, and take out filters.

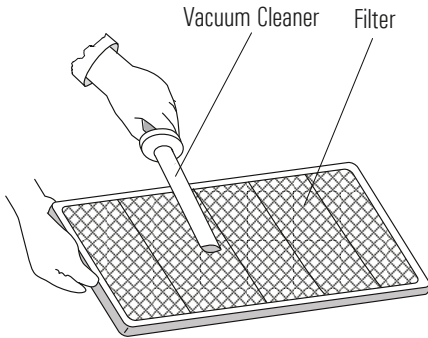

2. Step: Clean the filters by vacuum cleaner. For deep clean use natural soap and water mixture, bathe the filter in that mixture. Dont push and scrub the filter while cleaning. Let the filter dry before use on unit.

Note: For F Class filter do not clean filter. Only change it.

Heat Recovery Exchanger Cleaning

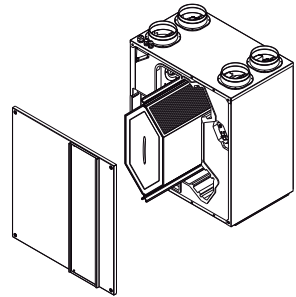

1. Step: Unscrew the filter service door then take out main door. Take out heat exchanger by hand gently.

Note: Heat exchanger max.weight is 5.5kg.

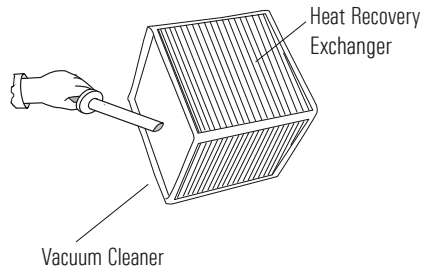

2. Step: Only clean with vacuum cleaner (Not use water or chemical material).

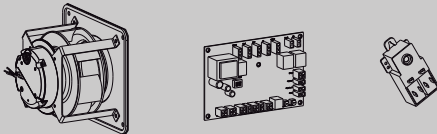

** For fan, control unit and actuator service points see previous pages.

SELECTION OF ELECTRICAL CABLE CROSS-SECTION

Unit Model	Unit Voltage (V)	Unit Power Input (kW)	Current (A)	Fuse (A)	Cable Cross-Section (mm ²) for 50M and PF=0.8
EVENT					
300	230	0.11	1	1	1.5
500	230	0.17	1.68	2	1.5
700	230	0.35	2.88	3.15	1.5

The data in the table shows the maximum power/current values. Please check unit label for updated values.

Cable Cross-Section Formulas

1

$$I_{\text{current}} = \frac{P}{U \cdot \text{Cos}\phi}$$

$$I_{\text{cable}} > I_{\text{current}}$$

2

$$\%e = \frac{100 \cdot P \cdot L}{k \cdot S \cdot U^2}, \quad S = \frac{100 \cdot P \cdot L}{k \cdot \%e \cdot U^2}$$

$$\%e = \%3$$

3

$$I_{\text{cable}} > I_{\text{fuse}} \geq I_{\text{current}}$$

$$\text{Cable Cross-Section } S = \text{Max}(S1, S2, S3, 1.5\text{mm}^2)$$

P : Power

I : Current

U : Voltage

S : Conductor cross section

k : Conductor coefficient

L : Conductor length

%e: The voltage drop

Example of Cable Cross-Section Calculation

P : 0,169 kW

L : 50m

U : 230V

%e : %3

PF : Cosϕ : 0,8

k : 56m / Ω

1

$$I_{\text{current}} = \frac{166 \text{ W}}{230 \cdot 0,8} = 0,9 \text{ A}$$

The cable will be used, is selected from the cable cross-section table so that the equivalent ampere value in the table should be higher than calculated "I_{current}" value.

$$S1 = 0,5 \text{ mm}^2$$

2

$$\%e = \%3$$

$$S = \frac{100 \cdot 166 \cdot 50}{56 \cdot 3 \cdot 230^2} = 0,09 \text{ mm}^2$$

$$S2 \geq 0,09 \text{ mm}^2 \geq 0,5 \text{ mm}^2$$

$$S2 = 0,5 \text{ mm}^2$$

3

$$I_{\text{cable}} > I_{\text{fuse}} \geq I_{\text{current}}$$

$$I_{\text{cable}} > 0,5\text{A} \geq 0,09\text{A}$$

"I_{fuse}" which will be higher than "I_{current}", is selected.

The cable will be used, is selected from the cable cross-section table so that the equivalent ampere value in the table should be higher than selected "I_{fuse}" value.

$$I_{\text{cable}} = 12\text{A}$$

$$S3 = 0,5 \text{ mm}^2$$

$$\text{Cable cross-section } S = \text{Max}(S1, S2, S3, 1,5 \text{ mm}^2)$$

$$S = \text{Max}(0,5, 0,5, 0,5, 1,5)$$

$$S = 1,5 \text{ mm}^2$$



Warranty Certificate

- * If the unit is used according to the instructions given in user manual and interfered in only authorized technical service that we authorize about any maintenance and repair reasons, all spare parts will be under warranty for 2 years against material, labor and production faults except motor components.
- * Identifying of parts replaced and determining troubleshooting technical procedure applied, will belong to our company.
- * After ex-works of goods, all faults during loading, unloading and shipment will be out of guarantee. If a falsify has been made on documents or any falsify and changing have been made on serial number, goods will be out of guarantee.

Terms of Guarantee

1. Guarantee period is 2 years as from the time of delivery.
2. All spare parts except motor components are under warranty.
3. If the goods break down during guarantee period, the time spent for maintenance will be added to guarantee period. Maintenance period is 30 days at most. 30 days begin with the notice to a service station. If there is no service station, 30 days begin with the notice to the seller, dealer, agency, agent, importer or manufacturer of the goods.
4. If production fault occurs during guarantee period; the cost of new spare part and labor will not be claimed from the customer.
5. If a fault occurs because of not using or assembling according to the instructions given in user manual, goods will be out of guarantee.

UNIT TYPE

SERIAL NO

ENEKO Havalandırma ve İsi Ekonomisi
Sistem Teknolojileri Makina San. ve Tic. A.S.
10049 Sokak No: 04 AOSB Cigli/İZMİR
Tel: 0.232.328 20 80
Web Address: www.eneko.com.tr

SIGNATURE:



www.eneko.com.tr

ISTANBUL

 Cevizli District, Zuhul Avenue, Fusun Street, Ritim Istanbul
A5 Block Floor: 25 No: 137, 34846 Maltepe/Istanbul - TURKEY

 +90 216 455 29 60 / +90 216 455 29 61

 +90 216 455 29 62

 satis@eneko.com.tr

IZMIR

 10049 Street No: 4 I.A.O.S.B.
Cigli/Izmir - TURKEY

 +90 232 328 20 80

 +90 232 328 20 22

 info@eneko.com.tr





ENECON PLUS



Automation User Manual



Introduction	Page 1
Warning & Safety Information	Page 2
Enecon Plus Standard Panel	Page 3
Control	Page 3
Fault List	Page 8
Warning List	Page 8
Service Menu Usage	Page 9
MODBUS RTU Settings	Page 9
MODBUS Register List	Page 10
Control Systems	Page 16

INTRODUCTION

This Automation User Manual has been prepared for the correct installation and use of the control systems of the units manufactured by ENEKO A.Ş. The Automation user manual contains description of the unit, components and basic informations and recommendations for proper and fail free operation. Please read the instructions and warnings given in this manual before starting installation, operation and maintenance works and keep this manual near the unit, within easy reach of service personnel.



Any damage, failure or hazard occurred because of use except this purpose is beyond the responsibility of manufacturer.



For technical service and questions, please contact with following information.



+90 232 328 20 80 / 103-152



+90 536 713 10 00



www.eneko.com.tr



servis@eneko.com.tr



PROHIBITED

- ◆ This unit has to be used under proper conditions according to its technical specification and design purpose. (Otherwise responsibility belongs to practitioner)
- ◆ Unauthorized personnel must not interfere in unit and/or must not use unoriginal spare parts. (Otherwise responsibility of failure that may occur belongs to practitioner)
- ◆ Do not use this control system other than the operating conditions specified in the installation and maintenance manual of the device. Do not use this control system in environments exposed to rain. (Otherwise, it may cause electric shocks or malfunction of the device)
- ◆ Do not use this unit in acid, alkali or organic solvent vapors, paint or other toxic gases, gases containing corrosive substances, or in environments with high concentrations of oily smoke. Failure to heed this warning may result not only in the control system malfunctioning, but also in fire, electric leakage, and electric shock.



ATTENTION

- ◆ The relevant connection diagram is on the cover of the panel.
- ◆ Use the designated electrical wires for the terminal board connections and connect the wires securely so that they will not be disconnected. (Failure to ensure proper connections may result in fire.)
- ◆ In the ducts passing through the building, in the parts of the ducts that are in contact with the building construction, make sure that the ducts are not in any electrical contact with the metal parts. (Electric leaks can cause fire and explosion.)
- ◆ Gloves should be worn while installation. (Failure to heed this warning may result in injury.)
- ◆ A dedicated circuit breaker must be installed at the origin of mains power supply. This circuit breaker must be provided with a means for locking (lock and key).
- ◆ The unit, the room control panel and cables must be at least 3 meters away from equipment or cables that create a high electromagnetic field. (Otherwise it may cause the device not to work.)
- ◆ During the replacement of spare parts, the layout of the panel must be maintained and the part must be assembled as it came from the factory.



This product must not be disassembled under any circumstances. Only authorized repair technicians are qualified to conduct disassembly and repairs.
(Failure to heed this warning may result in fire, electrical shock or injury.)



Connect the product properly to the ground. (Malfunctioning or power leaks can cause electrical shock.)



An isolator switch having minimum contact gap of 3 mm in all poles must be provided as a means of disconnecting the power supply.

NOTE: The installations, which is not available for installation and otomation manual, is out of guarantee.

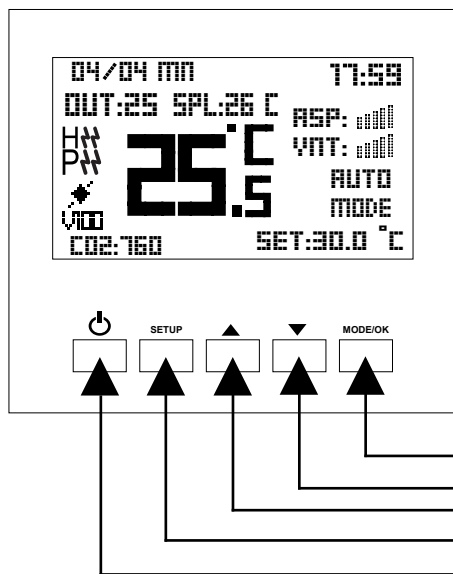

- 3.1" Graphic Panel
- Aspirator, Ventilator 6 Level Speed Control
- Automatic / Manual Mode
- Heating / Cooling / Fan Mode
- Language Option
- Internal Return Air Temperature Input
- Minimum & Maximum Set Temperature Limit
- Weekly Program

- Mode/Ok
- Down
- Up
- SetUp
- On/Off

Technical Specifications

Environmental Specifications	
Operating, Stock Temperature	0 ... +50°C (There should be no icing or condensation in the environment.)
Electrical Specifications	
Control	Digital Wall Panel (Max. 30 m) / Building Automation
Relay Current Capacity	Resistive 5A (Heater Contactor)
Supply	230V AC Outputs

CONTROL

Fan Speed Control Function

Control board has 7 different fan speeds. These fan speeds are set to specific values by default. The maximum fan speed is "boost". If it is desired to change fan speeds, set values can be changed by control panel and service menu parameters. If the device is on and in manual or fan mode, it is brought to the state that ASP or VNT is flashing by pressing **Mode/OK** button and ASP, VNT level is adjusted with ▲ and ▼ buttons.

Service parameter:

- 3 Aspirator Fan Manual Speed Value
- 4 Ventilator Fan Manual Speed Value

Mode Selection

- Mode selection can be made by pressing the **Mode/OK** button on the panel when the device is on.
- If the device is in Manual Heating or Automatic Heating, the set temperature is selected by pressing **Mode/OK**.
- In the manual heating and automatic heating mode, if the **Mode/OK** button is pressed while in the set temperature setting section, the next mode is entered directly.
- If the device is in Automatic mode, you can switch to the next mode by pressing **Mode/OK**.

Temperature Settings

- If the device is in manual or automatic heating mode when the device is on, the set temperature is set to flash by pressing the **Mode/OK** button and the set temperature is adjusted with the **Up** and **Down** buttons.
- If the device is in manual or automatic heating mode when the device is on, the set temperature is set to flash by pressing the **Mode/OK** button and the set temperature is adjusted with the **Up** and **Down** buttons.

Filter Function (Optional)



This function controls filter change time. There are 2 alternatives to control filters:

1. It records run time of the unit. Filter change time is set a particular run time by factory settings. When set time expires, control board gives an alert (red warning light flashes) for filter change.

Note: The instant filter time can be monitored from Parameter 115.

2. Filter change time can be controlled by pressure switch mechanically. With this method, when filter needs to be changed, control board gives an alert.

By-pass Function (Optional)

	By-pass is off.
	By-pass is on.

By-pass function only exists on units which have by-pass module. It is used when filtered fresh air is desired to be supplied to indoor without passing through heat exchanger (transition seasons). Control board decides whether by-pass module will be opened or not by controlling outdoor air temperature, return air temperature and set temperature values.

Note: By-pass status can be monitored from the 44th parameter of the service menu (0: Closed / 1: Open)

Electrical Pre-heater Function (Optional)

It is used to prevent icing inside the device in regions where the outside temperatures are very low. It works gradually depending on the outside temperature. The opening temperature of the preheater is set to 0 °C by default. It can be changed in the service menu.

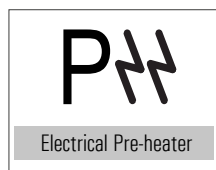

Note1: If a pre-heater is connected, the terminals specified in the electrical diagram of the device can be used directly. In order to receive the electric preheater alarm, the connection must be made by removing the jumper at the relevant terminal.

Note2: Pre-heater step can be monitored from the 63th parameter of the service menu. The heater thermostat information can be monitored from the 20th parameter.

Electric Heater Control Function (Optional)

Electric heater control function only exists on units which have duct type electric heater. This function controls electric heater that is used to increase temperature of supply air. It runs due to the return air temperature and set temperature values. 1 or 2 steps electric heater can be controlled.

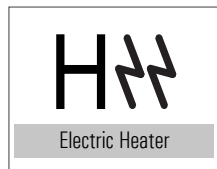

Note1: If an electric heater is connected, the terminals specified in the electrical diagram of the device can be used directly. In order to receive the electric preheater alarm, the connection must be made by removing the jumper at the relevant terminal.

Note2: Electric heater step can be monitored from the 62th parameter of the service menu. The heater thermostat information can be monitored from the 20th parameter.

Heating Coil Function (Optional)

This function is used in units which have duct type hot water coils. It controls the hot water coil which helps to increase supply air temperature and works due to set and return air temperature. It can control 230V On/Off valve connected to water coil. It can also control proportionally.

Note: H100 / V100 indicates that 100% output is given to the heating coil.

Cooling Coil Function (Optional)

This function is used in units which have duct type cold water coils. It controls the cold water coil which helps to decrease supply air temperature and works due to set and return air temperature. It can control 230V On/Off valve connected to water coil. It can also control proportionally.

Note: C100 / V100 indicates that 100% output is given to the cooling coil.

Frost Protection Function (Optional)

Condensation occurs inside the unit where outdoor air temperature is below 0°C. Heat exchanger can be damaged if condensation water freezes inside. Control board changes fan speed periodically to protect freezing. When the temperature drops below the specified value, one or more of the following scenarios can be used;

1. The speed of the blower fan can be reduced (Parameter 518),
2. It will be active if there is a pre-heater (Parameter 513),
3. It will be active if there is a by-pass. (Parameter 160-153).

Bms Function (Optional)

BMS Function makes the unit to be monitored on a central automation system. Terminals on the control board can be used for the BMS connection.

Boost Function

It is used to provide for high amounts of exhaust and fresh air that will occur due to any effects that may occur in the environment (such as bad smell in the kitchen, using the bathroom and / or toilet) while the device is operating in any location. When **BOOST** mode is activated, the fans are fully operated. After working for the specified **BOOST** time, the device continues to operate normally.

1. **BOOST** terminals can be used as shown in the electrical diagram (optional)
2. It can be activated using parameter 117 of the service menu.

Note: BOOST time can be changed.

Fire Function (Optional)

There is a dry contact relay on the control board. The fire function is activated in case of on fire, if the dry contact relay is attached to fire system.

Note : Fire scenario can be selected from parameter 144 of service menu.

Sensor (VOD) (Optional)

It operates with CO₂, air quality or humidity sensor connection. Fan speeds are automatically changed according to the data from these sensors.

Note: The sensor value can be monitored from the service menu and panel screen:

- 27 Humidity Value
- 28 Air Quality Value
- 29 CO₂ Value parameters
- 38 CO₂ Set Value
- 39 Humidity Set Value

Note: If a CO₂ sensor will be added when the unit is in the field, the following parameters must be changed.

Parameter	Description	CO ₂ Config. Value
381	Analog Input 1 Type Selection	1
321	Analog Input 1 Min Value	0
331	Analog Input 1 Max Value	2000
530	Humidity control Open/Close	0
38	CO ₂ set value	0..2000
102	Full auto mod	1
529	CO ₂ control type	2
114	Analog value screen	1

Note: If a humidity sensor will be added when the unit is in the field, the following parameters must be changed.

Parameter	Description	Hum. Config. Value
381	Analog Input 1 Type Selection	3

Parameter	Description	Hum. Config. Value
321	Analog Input 1 Min Value	25
331	Analog Input 1 Max Value	155
530	Humidity control Open/Close	1
39	Humidity set value	0..100
114	Analog value screen	3

Date and Time Settings

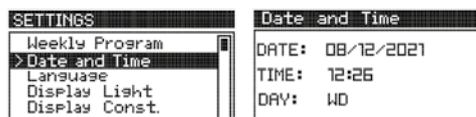

- While the device is on, press the Setup button on the panel for 2 seconds.
- Select Date Time Setting with the Down button and press the **Mode/OK** button.
- Select the day, month and year setting with the **Up and Down** button and proceed using the **Mode/OK** button.
- Select the hour and minute settings with the **Up and Down** buttons and proceed using the **Mode/OK** button.
- Select the day with the **Up and Down** button and scroll using the **Mode/OK** button and turn **On/Off** Exit with the button.

Weekly Program Settings

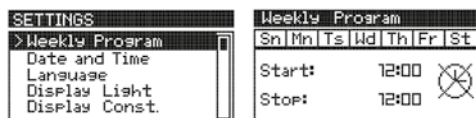

Weekly timer function is available on Panel. Unit can be programmed to operate automatically on certain periods of the week.

- While the device is on, press the Setup button for 2 seconds on the panel, while the weekly program is selected, press the **Mode/OK** button.
- Select the day to be adjusted by using the **Up and Down** buttons and the **Mode/OK** button.
- While Start is written, the start time of the device is set. Proceed with the **Mode/OK** button and set the end time of the device when Stop is written and save with the **Mode/OK** button.
- The same process steps are repeated for the other days, and the start and end times are adjusted as desired.
- After the weekly program is made, it is returned to the main screen with the **On/Off** button.

Note 1: If the start time is after the endtime, the device remains off during the selected day.

Note 2: If the start time and end time are the same, the weekly program application will not work for the selected day.

Note 3: If the device has a weekly program setting for the current day, the clock logo appears on the screen and operates with in the programmed working hours.

Note 4: If the device is programmed weekly for the current day and is within the programmed working hours, the clock stop logo appears on the screen.

: The weekly program is active and the device stops.

: The weekly program is active.

The Key Lock/Unlocked



- The key lock is unlocked by pressing the **Setup** and **Down** button for 5 seconds in the open position.
- If you want to close the key lock, the key lock is turned off by pressing **Setup** and **Down** again for 5 seconds.

Fault Reset Setting

If the fault code flashes in the upper corner of the screen and the fault is fixed, the fault is reset by pressing the **Setup** button and **Up** button at the same time while the screen is on.

Note: Before resetting the filter dirty alarm, the filter must be changed by the technical service.

FAULT LIST

Value		Binary	Explanation
E	1	0000.0000.0000.0001	Aspirator Fan Failure
E	2	0000.0000.0000.0010	Vantilator Fan Failure
E	4	0000.0000.0000.0100	Electrial Heater Failure
E	8	0000.0000.0000.1000	Aspirator Air Flow Error
E	16	0000.0000.0001.0000	Vantilator Air Flow Error
E	32	0000.0000.0010.0000	Compressor Failure
E	64	0000.0000.0100.0000	Low Pressure
E	99	-	Communication Error
E	128	0000.0000.1000.0000	High Pressure
E	256	0000.0001.0000.0000	Fire Alarm
E	1024	0000.0100.0000.0000	VRF Error

WARNING LIST

Value		Binary	Explanation
W	1	0000.0000.0000.0001	Closed By Building Automation System
W	2	0000.0000.0000.0010	Boost Mode
W	4	0000.0000.0000.0100	Filter 1 Dirty
W	8	0000.0000.0000.1000	Filter 2 Dirty
W	16	0000.0000.0001.0000	Defrost Mode
W	32	0000.0000.0010.0000	Freezing Thermostat
W	64	0000.0000.0100.0000	Emergency
W	4096	1000.0000.0000.0000	Maintenance Alarm

To log in to the user service menu:

- Press the **Up** and **Down** buttons simultaneously through the panel while the device is energized.
- On the screen you see, use the **Up** and **Down** buttons to enter the service password and press the **Mode/OK** button.

Note: The service password: "58"

- If the password is entered correctly, enter the parameter number you want to change on the display and press the **Mode/OK** button.
- After changing the parameter you want to change, register by pressing the **Mode/OK** button and go to the main menu with the **On/Off** button.
- Press the **On/Off** button to exit the service menu.



Changes to be made in the service setting menu must be made by the relevant technical personnel. All responsibility arising from these changes belongs to the person who changed the device parameter.

MODBUS RTU SETTINGS

To log in to the user service menu:

- Press the **Up** and **Down** buttons simultaneously through the panel while the device is energized.
- On the screen you see, use the **Up** and **Down** buttons to enter the service password and press the **Mode/OK** button.
- If the password is entered correctly, enter the parameter number you want to change on the display and press the **Mode/OK** button.
- After changing the parameter you want to change, register by pressing the **Mode/OK** button and go to the main menu with the **On/Off** button.
- For Modbus ID, the "PR" parameter is reached 111, and using the desired Modbus ID **Up** and **Down** buttons, set "ST" and press the **Mode/OK** button.
- For Modbus ID, the "PR" parameter is reached 112, and using the desired Modbus baudrate **Up** and **Down** buttons, set "ST" and press the **Mode/OK** button.
- Press the **On/Off** button to exit the service menu.

0: 1200 Bps

1: 2400 Bps

2: 4800 Bps

3: 9600 Bps

4: 19200 Bps

5: 38400 Bps

6: 57600 Bps

Note 1: All Modbus parameters are Holding register.

Note 2: All Modbus parameters are Signed Integer 16.

MODBUS REGISTER LIST

PLC Register				
40001	0	Device Open / Close Variable	0...1	0: Off 1: On
40002	1	Device Set Temperature	0...999	280 value means 28 °C.
40003	2	Device Air Conditioning Mode	0...5	0: Fan Mode 1: Man. Heating 2: Man. Cooling 3: Auto Heating 4: Auto Cooling 5: Full Automatic Mode
40004	3	Aspirator Fan Manuel Speed Value	0...6	
40005	4	Ventilator Fan Manual Speed Value	0...6	
40007	6	Panel Ambient Temperature Value	-400...999	It is the Temperature Value on the Panel.
40008	7	Device Fresh Air Temperature Value	-400...999	It shows the temperature of the air drawn in the space.
40009	8	Device Supply Air Temperature Value	-400...999	If there is no temperature value available on the device, the temperature value is seen as "32767".
40010	9	Outdoor Temperature Value	-400...999	
40011	10	Water Coil Temperature Value	-400...999	
40015	14	Bms Input	0...1	0: Device Operates Normally., 1: The device is turned off.
40016	15	Boost Input	0...1	0: It works normally., 1: Fans are working fully.
40017	16	Aspirator Fan Air Flow Information	0...1	Aspirator Fan Air Flow Switch information.
40018	17	Ventilator Fan Air Flow Information	0...1	Ventilator Fan Air Flow Switch information.
40019	18	Filter 1 Dirty Information	0...1	Filter 1 DPS State
40021	20	E. Heater Safety Thermostat Information	0...1	Safety Thermostat Information
40022	21	Aspirator Fan Thermal Fault Information	0...1	Aspirator Fan Fault Information
40023	22	Ventilator Fan Thermal Fault Information	0...1	Ventilator Fan Fault Information
40024	23	Emergency Stop Button Information	0...1	Emergency Stop Button Information
40025	24	Low Pressure Inlet Information	0...1	Low Pressure Input
40026	25	High Pressure Information	0...1	High Pressure Input
40027	26	Fire Information	0...1	Fire Entry
40028	27	Freezing Thermostat Information	0...1	Freezing Thermostat Information (In Water Coil application, the valve opens completely and the fans are completely turned off.)
40029	28	Compressor Thermal Failure Information	0...1	Compressor Thermic (If there is a compressor, the compressor turns off.)

MODBUS REGISTER LIST

PLC Register				
40030	29	Phase Fail Information	0...1	Phase Failure Information (The device is completely turned off.)
40031	30	Heat Exchanger Freezing Thermostat	0...1	
40034	33	Humidity Value	0...1000	This value is adjusted according to the analog input calibration parameter between 321 and 340.
40035	34	Air Quality Value	0...1000	
40036	35	CO ₂ Value	0...1000	
40037	36	Return Pressure Value	0...1000	
40038	37	Blowing Pressure Value	0...1000	
40039	38	Analog 1 Set Value		
40040	39	Analog 2 Set Value		
40044	43	Fresh Air / Suction Damper Motor	0...1	0: Off 1: On
40045	44	By-pass Damper Motor	0...1	0: Off 1: On
40046	45	Heating / Cooling Coil Valve Output	0...1	0: Off 1: On
40047	46	Heating Battery Open / Close Output	0...1	0: Off 1: On
40048	47	Cooling On / Off Battery Outlet	0...1	0: Off 1: On
40049	48	Compressor Output	0...1	0: Off 1: On
40050	49	Compressor 4 Way Valve Output	0...1	0: Off 1: On
40051	50	Device Operation Information Output	0...1	0: Off 1: On
40052	51	Device Fault Information Output	0...1	0: Off 1: On
40053	52	Device Warning Information Output	0...1	0: Off 1: On
40054	53	Aspirator Fan Run Output	0...1	0: Off 1: On
40055	54	Ventilator Fan Run Output	0...1	0: Off 1: On
40059	58	Rotary Outlet	0...1	0: Off 1: On
40061	60	Instant Aspirator Fan Output Value	0...6	Fan electric heater shows the instantaneous step value.
40062	61	Instant Ventilator Fan Output Value	0...6	
40063	62	Instant Electric Heater Value	0...3	
40064	63	Instant Pre Electric Heater Value	0...3	
40065	64	Aspirator Fan Analog Output Value	0...100	It shows the proportional output values.
40066	65	Ventilator Fan Analog Output Value	0...100	
40067	66	Proportional Heating Valve Output Value	0...100	
40068	67	Proportional Cooling Valve Output Value	0...100	
40069	68	Proportional Heating / Cooling Valve Output Value	0...100	
40070	69	Proportional By-pass Damper Output Value		

MODBUS REGISTER LIST

PLC Register				
40073	72	Start on Sunday Hour: Minutes	0...2359	The device operates between the start and end times within a day and the device switches off outside these hours. If the start and end times are equal, the device works continuously on that day. If the start time is more than the end time, the device is completely turned off on the day set. The set parameter is 1210 è Hour: Minute information is set as 12:10.
40074	73	Ending on Sunday Time: Minutes	0...2359	
40075	74	Start on Monday Hour: Minutes	0...2359	
40076	75	Ending on Monday Time: Minutes	0...2359	
40077	76	Start on Tuesday Hour: Minutes	0...2359	
40078	77	Ending on Tuesday Time: Minutes	0...2359	
40079	78	Start on Wednesday Hour: Minutes	0...2359	
40080	79	Ending on Wednesday Time: Minutes	0...2359	
40081	80	Start on Thursday Hour: Minutes	0...2359	
40082	81	Ending on Thursday Time: Minutes	0...2359	
40083	82	Start on Friday Hour: Minutes	0...2359	
40084	83	Ending on Friday Time: Minutes	0...2359	
40085	84	Start on Saturday Hour: Minutes	0...2359	
40086	85	Ending on Saturday Time: Minutes	0...2359	
40087	86	Instant Day	1...31	
40088	87	Instant Month	1...12	
40089	88	Instant Year	0...99	
40090	89	Instant Hour	0...23	
40091	90	Instant Minute	0...59	
40092	91	Instant Second	0...59	
40093	92	Instant Day of the Week	1...7	1: Sunday 2: Monday 3: Tuesday 4: Wednesday 5: Thursday 6: Friday 7: Saturday
40094	93	Instant Weekly Program Status	0...2	0: No Weekly Schedule 1: The device has a weekly program and the device is working. 2: The device is set up weekly and the device is stopped.
40096	95	Alarm Value	0...99	
40097	96	Warning Value	0...99	
40104	103	Keylock	0...1	0: Key Lock Off, 1: Key Lock On
40105	104	Major Fault Information	0...1	0: No Fault, 1: The device has been completely shut down.
40106	105	Compressor Failure Information	0...1	0: No fault in the compressor 1: There has been a fault that turns off the compressor.

MODBUS REGISTER LIST

PLC Register				
40109	108	Fan Quantity	1...2	1: Single Fan, 2: Double Fan
40110	109	Fan Step Value	1...6	
40112	111	Modbus ID	1...254	
40113	112	Modbus Baudrate	0...7	
40114	113	Monitoring Temperature Value	0...3	0: Do not Show 1: Outdoor Temp. 2: Supply 3: Two Temp.
40115	114	Analog Input Value	0...3	0: Do not Show 1: CO ₂ 2: Air Quality 3: Humidity
40116	115	Filter Time Counter	0-9999 Hour	This counter increases on an hourly basis as long as the Ventilator Fan is running.
40117	116	Device Operating Mode Information	0-100	0: Device Off, 1: Damper Opens, 2: The Fan Turns On, 3: Main Loop, 4: Valve Closes 5: Fan Turns Off, 6: Freezing Condition 7: Defrost Status, 99: Fault Status (Waiting forReset)
40118	117	Activate Boost	0-1	0: Deactivated, 1: Active
40119	118	Control Temperature Type	0-3	0: Panel Temperature 1: According to the Return Air Temperature 2: According to the Supply Temperature 3: According to Outside Air Temperature
40145	144	Fire Scenrio	0-3	0: Fans Off 1: ASP Full VNT Off 2: ASP Off VNT Full 3: 2 Fan Full On
40146	145	Heating Cooling Hysterezis	0-999	
40149	148	Boost Max. Operating Time	0-999 Min.	Boost turns off automatically after this time.
40150	149	Limiting Variable of Heater According to Fan	0-1	
40151	150	Pre heater On Time	1-999 Sec.	Pre-heater on delay time
40152	151	Pre heater Off Time	1-999 Sec.	Pre-heater off delay time
40153	152	Pre-heater Hysterezis	1...100	E.g; A value of 100 means 10.0 °C.
40154	153	Pre-heater Stage Ranges		
40155	154	Number of Pre-heater Stages	0-3	
40156	155	Heater On Time	1-999 Sec.	Heater on delay time

MODBUS REGISTER LIST

PLC Register				
40157	156	Heater Off Time	1-999 Sec.	Heater off delay time
40158	157	Heater Hysterezis	1...100	E.g; A value of 100 means 10.0 °C.
40159	158	Heater Stage Intervals		
40160	159	Number of Heater Stages		
40161	160	Pre-heater Set Temperature Value	-400...999	
40162	161	By-pass Hysterezis	1...999	
40163	162	Rotary Hysterezis	1...999	
40164	163	P Value for Valve PI control		
40165	164	I Value for Valve PI control		
40174	173	Heating Coil Freeze Protection Minimum Temperature Value	-400...999	Battery temperature in the Heating Coil If the sensor is below this temperature value it goes into freeze protection mode.
40175	174	Heating Coil Freeze Protection Maximum Temperature Value	-400...999	Battery temperature in the Heating Coil sensor during freeze protection if this freezing above the temperature value exits the protection mode.
40176	175	Heat Exchanger Freeze Protection Minimum Temperature Value	-400...999	Heat exchanger temperature sensor on the heat exchanger if it goes below this temperature value, the heat exchanger enters the frost protection mode with the bypass damper.
40177	176	Heat Exchanger Freeze Protection Maximum Temperature Value	-400...999	Heat exchanger temperature sensor on the heat exchanger While in frost protection mode, if the temperature rises above this value, the heat exchanger exits the frost protection mode.
40178	177	Filter protection warning time limit	1...9999	If the filter counter time exceeds this value gives a filter warning on the screen.
40182	181	1 Universal input status	-400...999	If one of the device's universal input digital inputs is selected, 0 or 1 appears in the register. 0: On 1: Off
40183	182	2 Universal input status	-400...999	
40184	183	3 Universal input status	-400...999	
40185	184	4 Universal input status	-400...999	
40186	185	5 Universal input status	-400...999	If one of the device's universal input digital inputs is selected, 0 or 1 appears in the register. 0: On 1: Off
40187	186	6 Universal input status	-400...999	
40188	187	7 Universal input status	-400...999	
40189	188	8 Universal input status	-400...999	
40202	201	1 Digital output status	0...1	

MODBUS REGISTER LIST

PLC Register			
40203	202	2 Digital output status	0...1
40204	203	3 Digital output status	0...1
40205	204	4 Digital output status	0...1
40206	205	5 Digital output status	0...1
40207	206	6 Digital output status	0...1
40208	207	7 Digital output status	0...1
40209	208	8 Digital output status	0...1
40222	221	Analog Input 1 status	-9999...9999
40232	231	Analog Output 1 status	-9999...9999
40233	232	Analog Output 2 status	-9999...9999
40234	233	Analog Output 3 status	-9999...9999
40235	234	Analog Output 4 status	-9999...9999
40262	261	Din 1 Input Normally Open/Closed Selection	0...1
40263	262	Din 2 Input Normally Open/Closed Selection	
40264	263	Din 3 Input Normally Open/Closed Selection	
40265	264	Din 4 Input Normally Open/Closed Selection	
40266	265	Din 5 Input Normally Open/Closed Selection	
40267	266	Din 6 Input Normally Open/Closed Selection	
40268	267	Din 7 Input Normally Open/Closed Selection	
40269	268	Din 8 Input Normally Open/Closed Selection	
40302	301	Din 1 Output Normally Open/Closed Selection	0...1
40303	302	Din 2 Output Normally Open/Closed Selection	
40304	303	Din 3 Output Normally Open/Closed Selection	
40305	304	Din 4 Output Normally Open/Closed Selection	
40306	305	Din 5 Output Normally Open/Closed Selection	
40307	306	Din 6 Output Normally Open/Closed Selection	
40308	307	Din 7 Output Normally Open/Closed Selection	
40309	308	Din 8 Output Normally Open/Closed Selection	
40361	360	Modbus Data Bit	0...1
40362	361	Modbus Parity	0...1
40363	362	Modbus Stop Bit	0...1

Universal inputs should be checked from the project and which input is used for what purpose.

Digital outputs should be checked from the project and which input is used for what purpose.

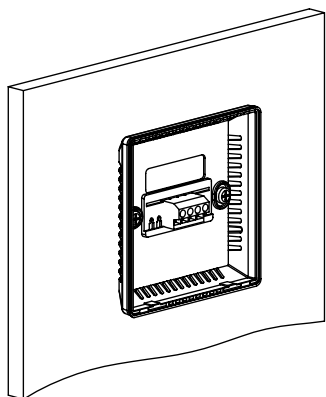

- With the help of a screwdriver, the back side is removed by pushing the tabs at the bottom of the panel.
- It is fixed to the wall with screws from the gaps on the plate.
- Bolts in $\varnothing 4 \times 30$ sizes and plastic dowels in $\varnothing 6$ sizes should be used.

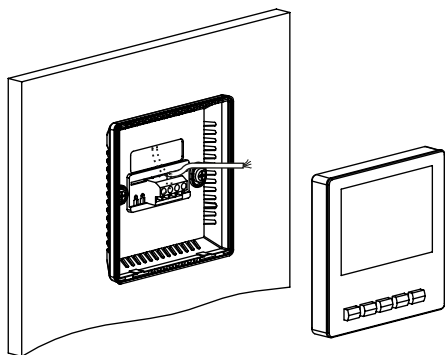

- The cable carried through the wall is passed through the cable gap on the back.
- Terminal connections related to the cable passed are made.
- First, the upper tabs on the front are replaced on the back.
- Afterwards, pressure is applied to the front of the panel so that the lower tabs on the front face are inserted into their places on the back.

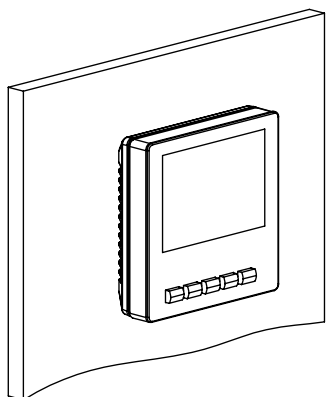

- The panel will be energized while the device is operating. Otherwise, the cable connections should be checked.



www.eneko.com.tr

ISTANBUL



Cevizli District, Zuhul Avenue, Fusun Street, Ritim Istanbul
A5 Block Floor: 25 No: 137, 34846 Maltepe/Istanbul - TURKEY



0216 455 29 60 - 0216 455 29 61



0216 455 29 62



satis@eneko.com.tr

IZMIR



10049 Street No: 4 I.A.O.S.B.
Cigli/Izmir - TURKEY



0232 328 20 80



0232 328 20 22



info@eneko.com.tr

